



OWNER`S MANUAL

DD-SERIES

DD33-40

600W /3 Channel Audiophile cool running Digital Amplifier



This product must be returned to the separate collection system for electronic products. Do not dispose this product together with general household waste.

DLS amplifiers are designed and engineered by:

DLS Svenska AB
Tagenevägen 11B
42259 Hisings Backa / Sweden
Tel: +46 31 840060
E-mail: info@dls.se
www.dls.se



Thank you and congratulations

Thank you for your decision to purchase a DLS amplifier!

Your DLS amplifiers must be installed correctly to perform at its best. This manual will show you how to install the amplifier like a pro. Please read the entire manual before beginning the installation. Install the amplifier yourself if you feel confident with our instructions and if you have the proper tools. However if you feel unsure, turn over the installation job to someone better suited to it.

Warranty Service

This amplifier is covered by warranty, depending on the conditions in the country where it is sold. If the amplifier is returned for service, please include the original dated receipt with the product.

Technical Assistance

For technical assistance ask the shop where the product was sold or the distributor in your very country. Information can also be found on our WEB-site www.dls.se

We follow a policy of continuous advancement in development. For this reason all or part of specifications & designs may be changed without prior notice.

DECLARATION OF CONFORMITY

DLS amplifiers for vehicles are manufactured in accordance with the EU directive EEC 95/54 (72/245/EEC) and are marked with the approval number. They are also marked in accordance with the WEEE-directive 2012/19/EU.

The products are also produced in accordance with the EU RoHS directive 2011/65/EU.



MOUNTING THE AMPLIFIER

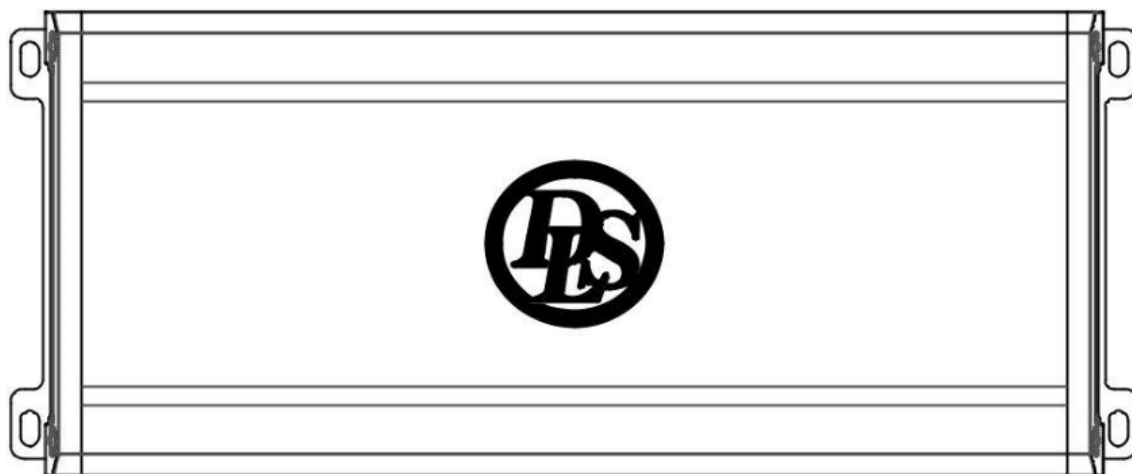

Fig.1 Mounting Amplifier

To keep your DLS amplifier running at top performance, choosing the proper location is of utmost importance. Both Thermal and Overload protection are built in.

In the event of overheating, the amplifier will turn off and only restart when cooled. For this reason the amplifier should be mounted in a location which will allow air to circulate freely. The compact size of the DLS DD Series amplifier allows greater flexibility in mounting.

CAUTION: Not water or mud proof. Cannot be submerged or it will void the warranty!

The models include the following features:

- FRD (Full Range Class-D)
- AUX Input
- Low profile design
- Digital Sound Optimization Circuitry
- High level input with auto start
- Powerful cable terminals
- Built-in active crossovers
- Remote sub level control
- High Damping Control Circuit
- Quiet Switching
- Advanced Protection Circuitry
- Virtual Silence Turn On/Off Mute
- 10-16 Volt



DD33-40 CONTROL PANEL LAYOUT

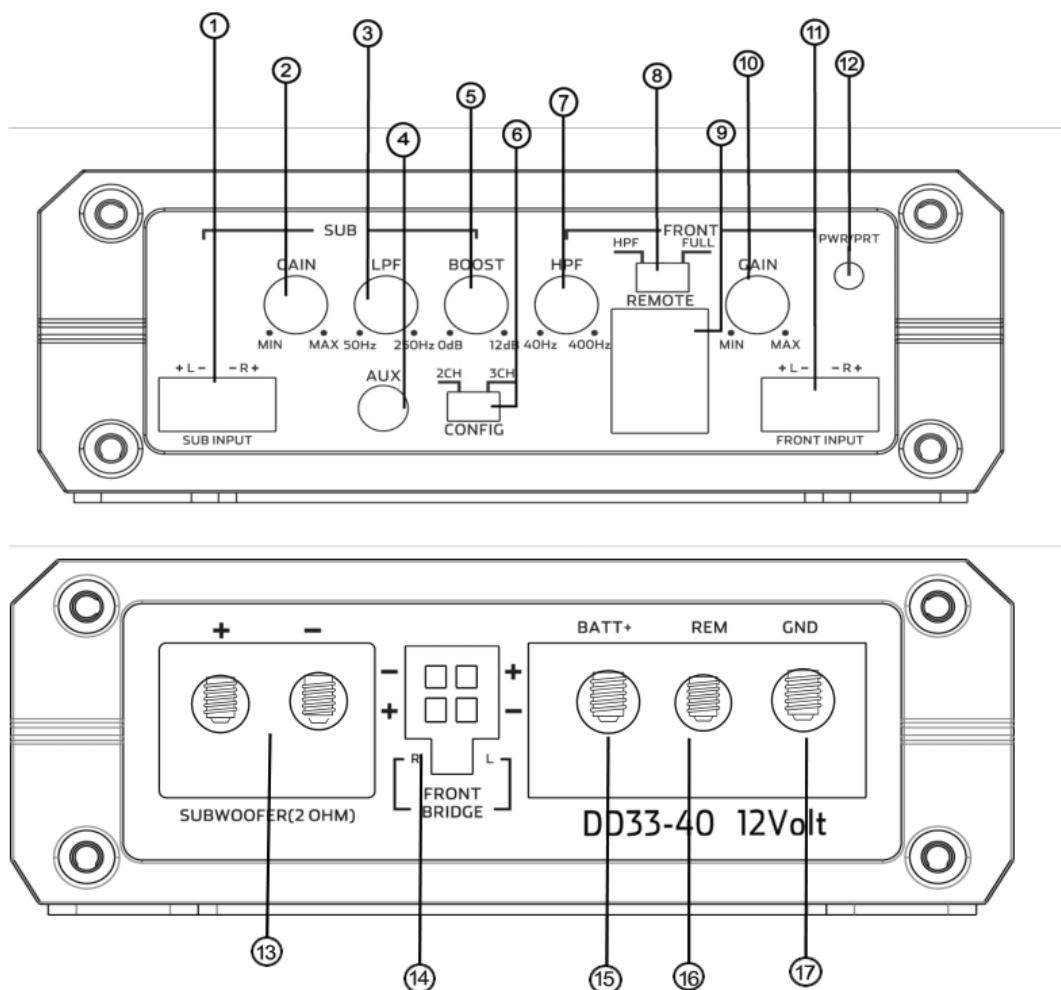

Fig. 2-3 Channel Panel Layout

1. SUBWOOFER INPUT Connector

This is both a Low and High Level Input port. Using the supplied wiring harness for low level RCA inputs or as instructed on Fig.9 High Level (speaker level) input.

2. SUBWOOFER GAIN Control

This control is used to match the input sensitivity of the amplifier to the particular source unit that you are using up to 250mV to 5 volts.

3. LPF (Low Pass Filter)

This control is continuously adjustable from 50Hz to 150Hz at 12dB per octave.

4. AUX Input Jack

This 1/8-inch (3.5mm) mini jack can be used to a MP3, iPod or Smartphone headphone output. NOTE: The amplifier INPUT switch needs to be in the 2CH setting when using AUX Input to provide signal for both front and sub amp section. In order to enable to keep the 3.5mm cable inserted in the AUX input it is internally parallel to the normal front input so it will not cut the signal from RCA / High level inputs but they will be very attenuated. If the radio sound still can be heard while playing through Aux just turn off the radio or lower the volume.~

Disconnect the Aux cable from the phone when not used to regain normal volume from the radio through RCA / High level inputs.

5. BASS EQ Control

This equalization circuit is used to enhance the low frequency response of the vehicle's interior. With up to 12dB of boost centered at 45Hz, the BASS EQ can be adjusted to meet your own personal taste.



6. INPUT Switch

Matches the input from the Source Unit to that of the amplifier, either 2 or 3 Channel with separate subinput. This eliminates the use of “Y” adapters and provides a cleaner input signal. When the 2-Channel mode is selected, both front and sub outputs will operate from front low level RCA / high level input.

When the 3-CH MODE is selected, both the front and subwoofer inputs will be used. This will allow balancing level between the front and subwoofer outputs.

7. HPF (High Pass Filter)

This control is continuously adjustable from 40Hz to 400Hz at 12dB per octave when the x-over switch is set to HPF.

8. X-OVER Switch for FULL/HPF

Activates the built-in electronic crossover network. Works in conjunction with the HPF adjustable control. When set to FULL the amplifier run full range and the electronic crossover circuitry is bypassed.

9. REMOTE LEVEL INPUT Connector

Connector port for the remote level controller. By this the subwoofer output level can be adjusted from the driver's seat.

10. FRONT GAIN Control

This control match the input sensitivity of the amplifier to the source unit from 250mV up to 5 volts.

11. FRONT INPUT Connector

This is both a Low and High Level input port. Using the supplied wiring harness for low level RCA inputs or High Level (speaker level) input.

12. POWER/STATUS Indicator

This clear LED lights Blue when the power is on, or turns Red constantly when the built-in protection circuitry is activated. Red indicates a problem with the system in relation to the amplifier /see troubleshooting tips).

13. SUBWOOFER OUTPUT

Set screw subwoofer output terminal. Be sure to observe the correct speaker polarity and follow the speaker wiring diagrams starting on page 21.

14. FRONT SPEAKER OUTPUT

This 4-pin Molex style connector is where the speaker output harness plugs in. Be sure to observe the correct speaker polarity and follow the speaker wiring diagrams starting on page 21.

15. BATT+ (Power Input Connection)

This terminal is the main power input for the amplifier and must be connected directly to the positive (+) terminal of the car battery. The solderless terminal block is designed to accommodate up to 4-gauge power wire.

FUSE-IMPORTANT

Due to the limited space on the DD amplifier chassis they do NOT come with user replacable fusing! use an in-line fuseholder that can be connected directly to the BATT+ input on the amplifier. Please note the proper ampere fuse for each model. Never replace a fuse with a higher rating then what is listed.

16. REM (Remote Input Connection)

This terminal must be connected to a switched +12V source. Typically, remote turn-on leads are provided at the source unit that will turn on and off like the ACC, +12V.

17. GND (Ground Input Connection)

A good quality ground is required for your DD33-40 amplifier to operate at peak performance. A short length of cable the same gauge as your power cable should be used to attach the ground terminal directly to the chassis of the vehicle. Make sure that all of the paint is sanded or scraped away to ensure a quality ground connection.

NOTE: If installing in a boat, UTV or motorcycle make sure your ground wire is connected to the negative (-) terminal of the battery.



POWER WIRING AND SIGNAL CONNECTIONS

*** WARNING ***

Disconnect the negative (-) battery terminal before you start any wiring work! The battery of your car audio system must be disconnected until the entire wiring installation is completed.

Your DLS DD amplifier requires unrestricted current to deliver peak performance, so do not “starve” your amplifier by using small power cable. Using under sized power cable can result in unnecessary over-heating of the amplifier, distortion at high volume levels and might even cause the thermal protection circuitry to shut off the amplifier. Remember, bigger wire is better!

- Use rubber grommets when running cables through any metal or sharp plastic, to prevent accidental shorting or shearing. Make sure the cables do not interfere with normal operation of the vehicle.
- The audio signal cables (RCA interconnects) should be kept far away from any potential sources of electrical interference such as electronic vehicle management systems (relays, engine computers etc.), wiring harnesses, fuel pumps etc.

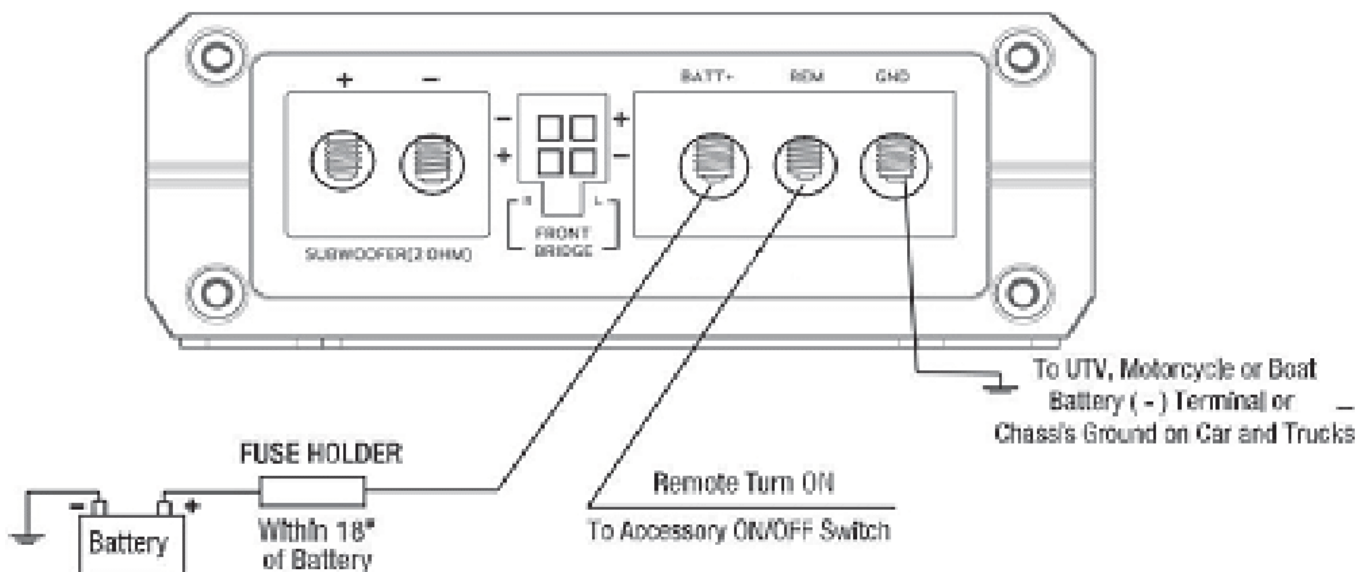

Fig.4 Power Input Connection

These amplifiers are designed to work within a 10 to 16 volt DC range. Before any wires are connected, the vehicles electrical system should be checked for correct voltage supply with the help of a voltmeter.

First, check the voltage at the battery with the ignition in the OFF position. The voltmeter should read no less than 12v. If your vehicles electrical system is not up to these specifications, we recommend having it checked by an auto electrician before any further installation. Once the vehicle is checked, make certain the correct cable gauge is used. The DD amplifier terminals are capable of accepting up to 8 gauge power and ground cable. We recommend using as large a gauge cable as possible, use the Power Cable Selection Chart to calculate the correct power wire size for your application.



POWER WIRING

BATT+ (Power)

This amplifier should be wired directly to the vehicle battery using the appropriate size cable. Start at the vehicle battery and run the power cable through to the amplifier. Avoid running the power cable over engine components and near heater cores.

The use of an inline fuse or circuit breaker is a must; this will prevent the risk of a potential fire caused by a short in your power cable. Connect the fuse holder or circuit breaker as close to the battery positive (+) terminal as possible (within 18" from the battery). You may now connect the cable to the battery, but remember to leave the fuse out or circuit breaker "off" until all other cable connections are made.

GND (Ground)

When grounding your amplifier, locate a metal area close to the amplifier that is good source of ground (preferable the floor pan). Use a short length of cable the same gauge as your power cable. Once again, investigate the area you wish to use for electrical wires, vacuum lines, and brake or fuel lines. Use either a wire brush or sandpaper to eliminate unwanted paint for better contact of the ground.

NOTE: If installing in a boat, UTV or motorcycle make sure your ground wire is connected to the negative (-) terminal of the battery. See Fig. 5

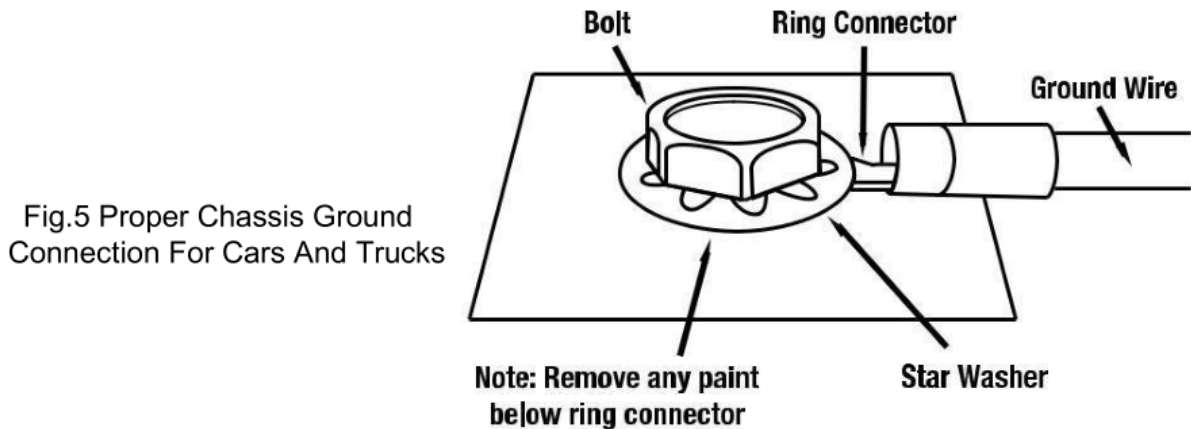

Secure the ground cable to the body using a bolt, star washer and nut. Spread silicon over the screw and bare metal to prevent rust and possible water leaks.

For Power Sport applications such as UTVs, motorcycles and boats it is highly recommended to wire both the Ground (GND) and Positive (BATT+) cables from the amplifier directly to the battery. **NOTE: The Ground must be capable of carrying the same amount of current as the positive wire.**

Now it's time to connect the power and ground cables to the amplifier. Cut both cables to length. Strip o 1/2 inch (12mm) of the insulation so that the bare wire fits all the way in the terminal block on the side panel of the amplifier, seating it firmly so no bare wire is exposed. Use a hex screw driver to lose the BATT+ and the GND connection on the amplifier. Insert the ground first, and then the +12V and please make sure that you place them into the correctly marked terminals. Hand tighten the set screws and make sure the connection is secure to prevent possible arcing due to lose screws.



REM (Remote Trigger)

This terminal must be connected to a switched +12V-source. Typically, remote turn-on leads are provided at the source unit that will turn on and off the amplifier in correspondence with the source. If the source unit does not have a remote turn-on lead, then a switched +12V supply must be used, like the ACC, +12V

Run a minimum of 18 gauge wire from the amplifier location to the source of the switched +12V lead. If possible, route this wire on the same side of the vehicle as your power cable. Connect the source remote output to the wire. Go back to the amplifier and cut the wire to length. Loosen the screw terminal marked REM on the amplifier using an Allen wrench. Insert the stripped (bare) portion of the wire into the terminal and tighten the screw securely.

CONNECTIONS TO AMPLIFIER FOR BATT+, GND, REM AND SPEAKERS

Amplifier features specially tooled solderless terminals for power (Batt +), ground, remote and speaker connection. For maximum transfer of voltage and signal the bare wire needs to be inserted as far as possible into the terminal before tightening the set screw. Hand tighten the set screw and make sure the connection is secure to prevent possible arcing due to loose screws.

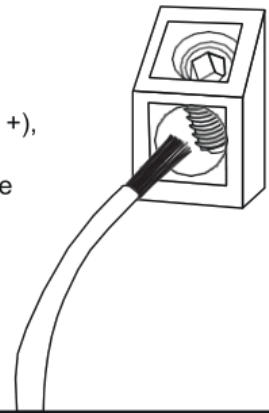

NOTE: It is highly recommended that an Hex wrench is used to tighten the set screws in the terminal blocks by hand and NOT a power drill. This will prevent stripping or other possible damage to the amplifier.



FUSE REQUIREMENTS

Due to the small size of the DLS DD series amplifiers, no fuses are incorporated into the panels that normally protect the unit from excessive current. Use an in-line fuse holder and fuse for this purpose.

Remember this fuse also protect the vehicle/vessel from a dangerous short circuit.

It is absolutely vital that the main power lead to the amplifier(s) in the system be fused within 18-inches (45cm) of the connection to the battery.

Proper Ground Connection For UTVs, Motorcycles or Boats

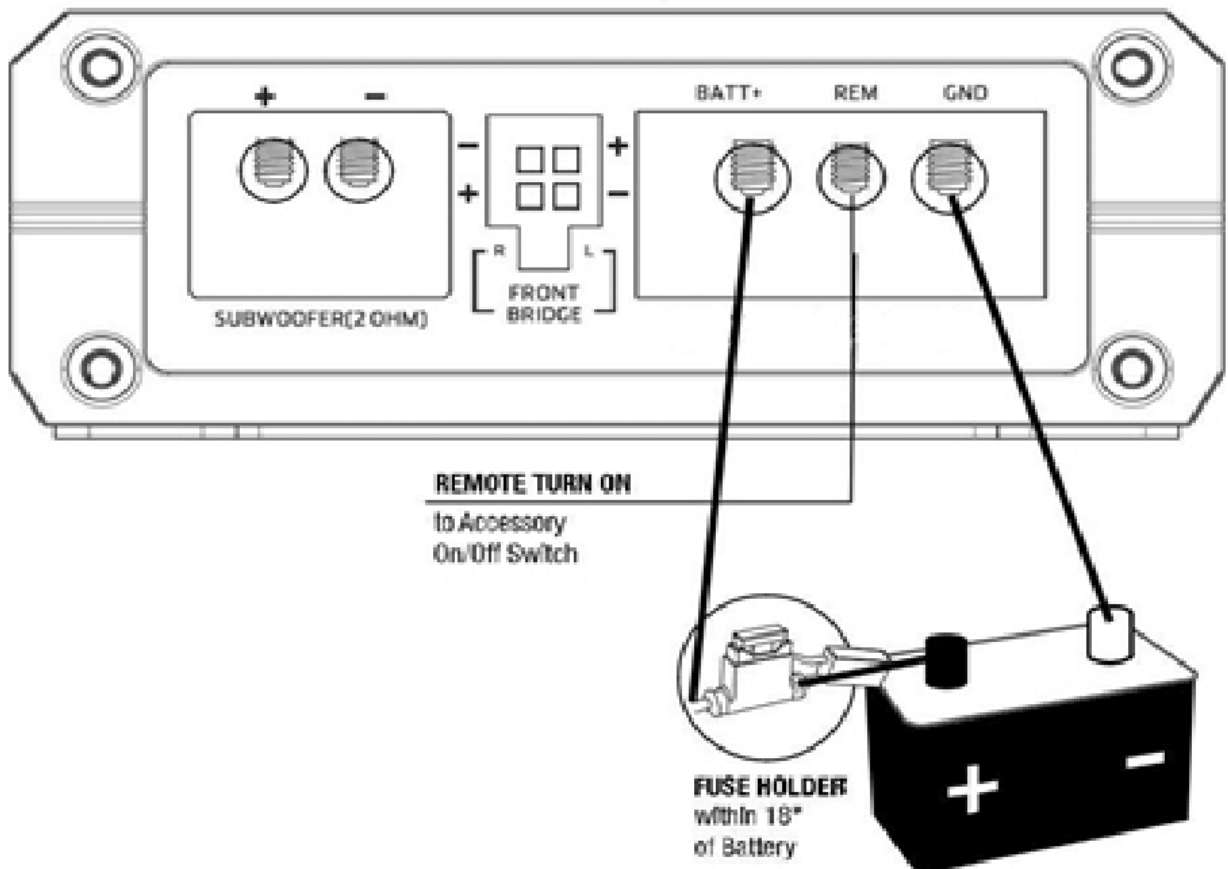
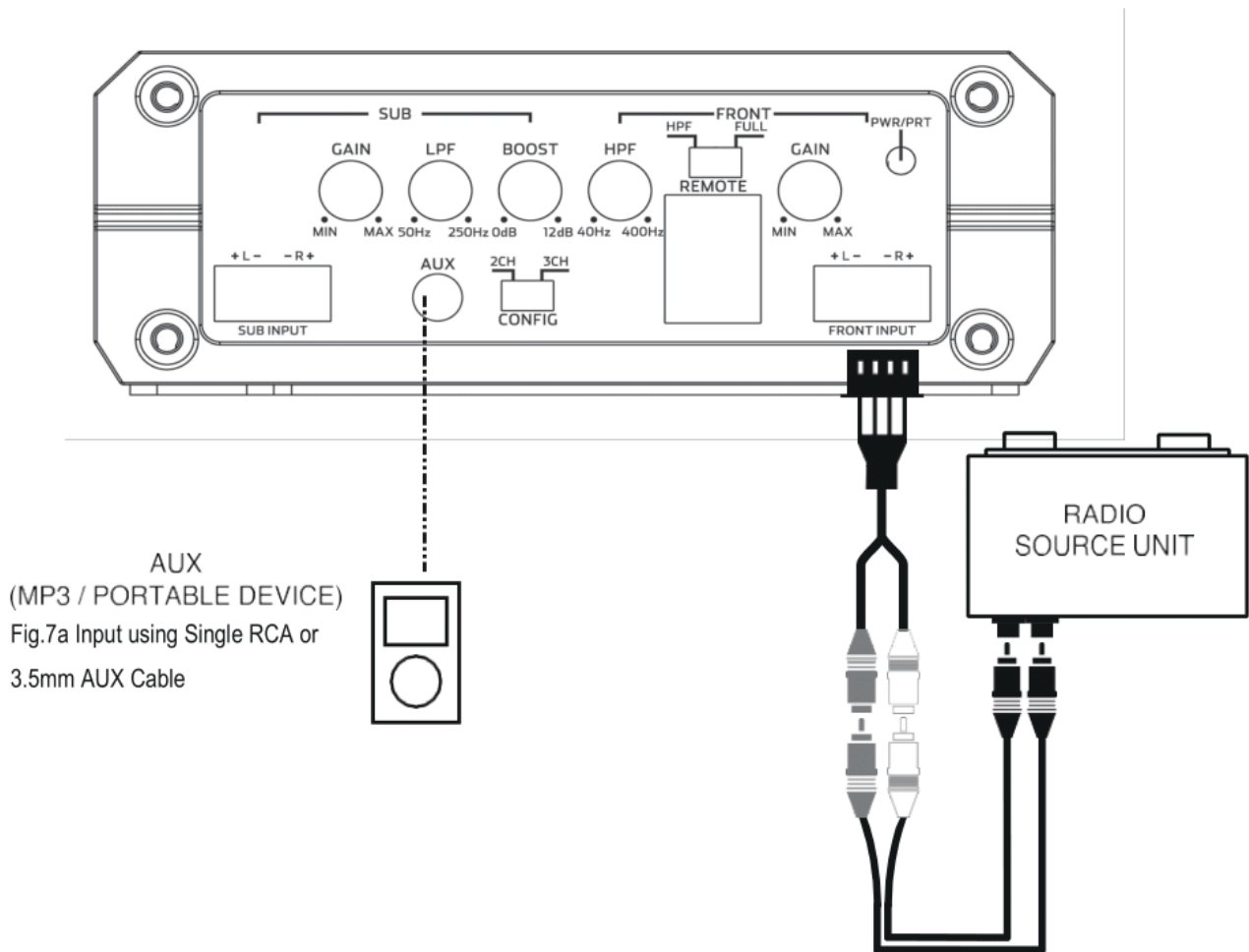

Fig.6 Proper Ground Connection For UTVs, Motorcycles or Boats



SOURCE INTERCONNECT

Single RCA / Low Level Input



AUX
(MP3 / PORTABLE DEVICE)
Fig.7a Input using Single RCA or
3.5mm AUX Cable

Choose the correct length and style of RCA interconnects for your needs. Always use high quality RCA audio cables (not supplied) for signal connections—those with multiple layers of shielding or a twisted pair variety for better noise rejection. Be extra careful when routing your RCA audio interconnect cables. Car environments are notorious for poorly insulated wires. This means that hiss, engine noise, and fan noise can easily be picked up through RCA cables if run incorrectly. Make sure that the cables for power and audio signal are not on the same side of the vehicle and that they do not cross each other; this will help reduce any noise that may radiate from the power cable and the signal cable. If an audio cable is too close to a power cable, it may pick up the magnetic field generated by the power cable, which could lead to a loss of quality in your signal.

Front / Sub input

Use RCA harness with Low level sources

Use HLC harness with High level sources, with the included special high level adapter the inputs can be used with speaker input signals.

Unique AUX input function

- The AUX Input is for use with MP3 players or an iPod® / Smartphone headphone output. Use of this input will not cut the RCA / High level inputs as normal Aux inputs but it will attenuate it as long as a source is connected to the Aux cable.
- When Aux input cable is connected to the phone it will lower the volume on RCA/High Level front input source. Please disconnect the Aux cable plug from the phone to have full volume from RCA / High level source back (even with the Aux cable still connected to the amplifier).
- Nominal Aux input sensitivity is slightly reduced when RCA/High level inputs are connected but it can normally be used in parallel without problem. If higher AUX sensitivity is required please disconnect RCA / High level front input from other source.

Note: INPUT switch needs to be in the 2CH setting when using AUX Input to provide signal for both front and sub amp section.



SOURCE INTERCONNECT

Dual RCA / Low Level Input (Front and Subwoofer)

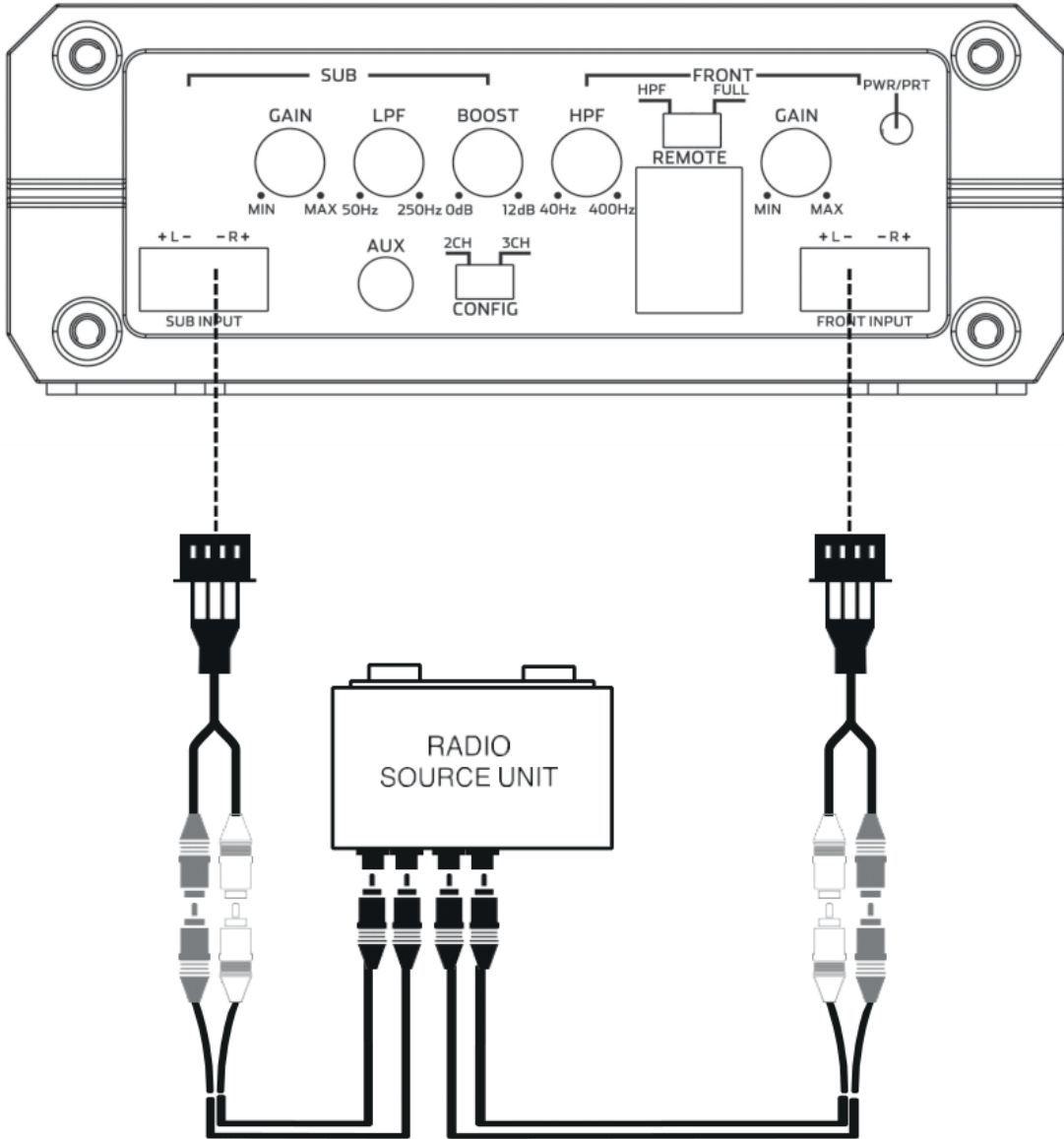

Fig.8 Input using two pairs of RCA cables



SOURCE INTERCONNECT

Single High Level / Speaker Input

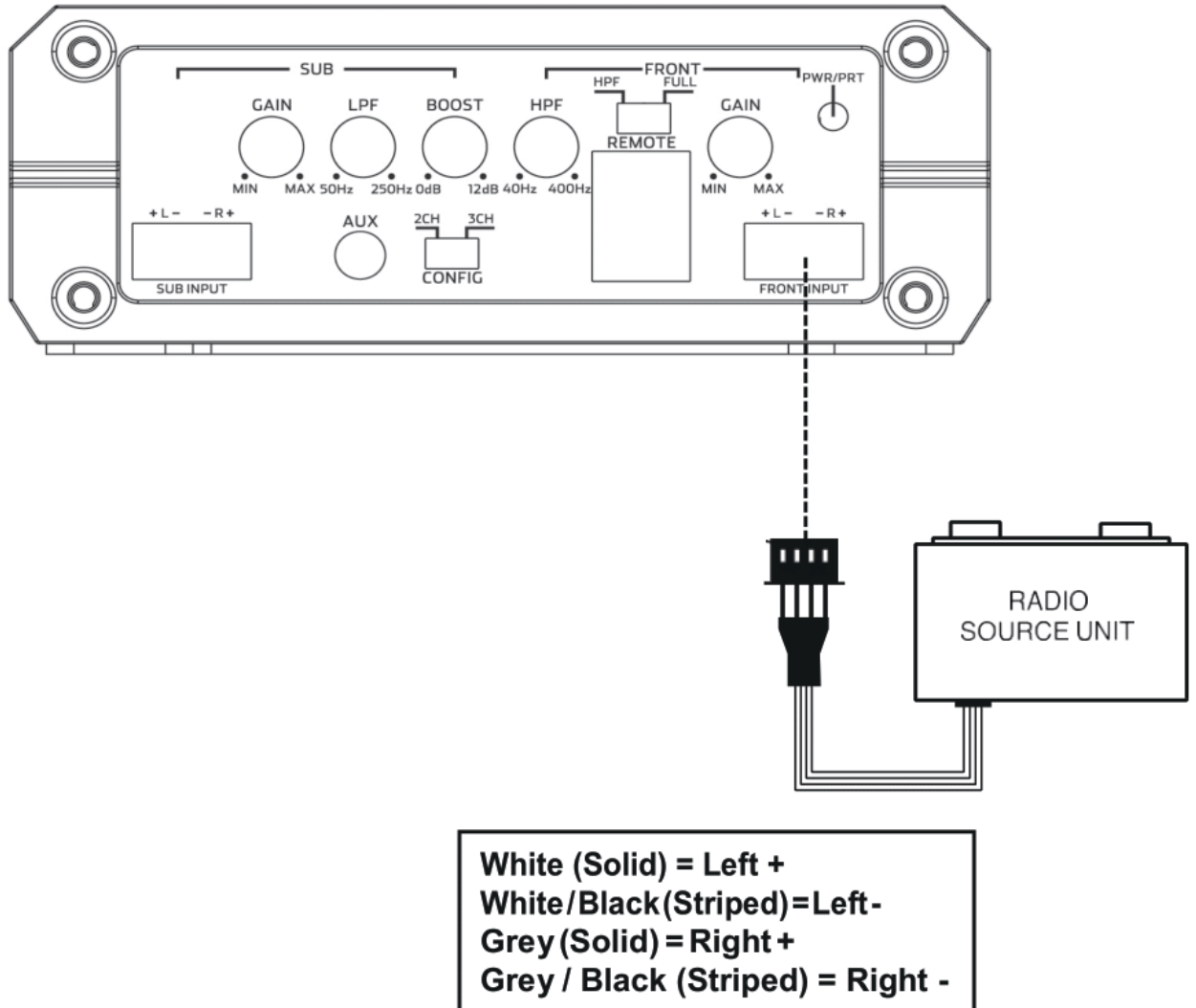

Fig.9 High Level / Speaker Level Input

- 1) To use speaker level inputs please connect the HLC harness to connector,
- 2) Connect the wires from the speaker output of the radio to the white and grey wires of the amplifier input wires using the color codes in above drawing.
- 3) If you are using both High Level / Speaker Inputs, make sure the MODE Selector switch is in the 3CH position



SET UP ADJUSTMENTS

INPUT Gain Adjustment



Control Panel (3) and (11)
GAIN Control

This control allows you to match the input level of the amplifier to the output level of your head unit. Matching the input can be accomplished in three simple steps:

1. Set the volume of GAIN on the amplifier to Min (completely counter clock wise).
2. Turn on the head unit and adjust volume to 2/3 maximum, and set the BASS to zero.
3. Adjust the GAIN control clockwise until the sound **just begins** to distort, then back o slightly to cut distortion and operate at optimum gain.

Remember, the **GAIN control is not a volume control** . Ignoring the three steps above may leave you with damaged speaker and/or a damaged amplifier.

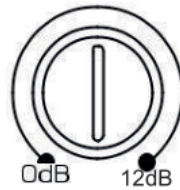

Control Panel (8)
Bass EQ Control

BASS EQ Control

This special feature is designed to provide you more powerful sound quality, and it allows you to increase the bass output up to +18dB at 45Hz (Sub Channel only). Keep in mind more is not always better. Setting the control to the max (12dB) may stress the amplifier and woofer and could result in damage.

NOTE: More is not always better. By turning the BASS EQ all the way up to 12dB you can overwork the amplifier and send the unit into thermal protection.

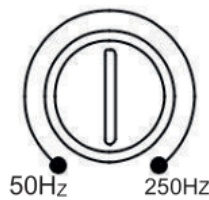

Control Panel (10)
Low Pass Control (LPF)

LPF (Low Pass Filter) Adjustment

Adjust the LPF frequency for your subwoofer(s) operation. Using the LPF control, adjust the Low Pass Frequency to limit the amount of midrange going to your subwoofers.

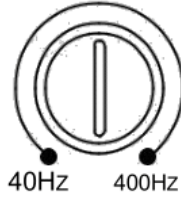

Control Panel (6)
High Pass Control (HPF)

HPF (High Pass Filter) Adjustment

When you are using coaxial or component speaker system, this allows you to adjust high-pass X-over frequency from 40Hz to 400Hz. To get better sound quality from coaxial or component speaker system, we recommend the frequency should be higher than 80Hz. Make sure the X-OVER switch is positioned at "HPF".

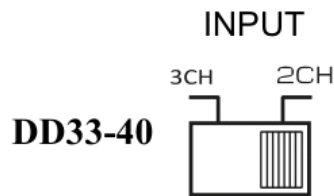

Fig.10 2-3 Channel Input Mode

Input Switch

Matches the input from the Source Unit to the amplifiers. This eliminates the use of "Y" adapters and provides a cleaner input signal. When the 2-Channel mode is selected, both front and sub outputs will operate with only one pair of low level RCA inputs.

AUX INPUT NOTE: The MODE switch must be in the 2CH position in order to use the 3.5mm AUX input

- 1) Using the 2CH Mode on the DD33-40 requires input signal to the Front Input connector.
- 2) Using the 3CH Mode on the DD33-40 requires both the Front Input and Subwoofer Input to be used. This will allow for fading between the Front and Rear/Subwoofer Outputs.



Fig.11 Connection with RJ12 Jack

REMOTE LEVEL Controller Connection

Your DLS DD33-40 amp includes a Remote Level control module. To connect the Remote Level Control to the amplifier, simply insert one end into the REMOTE LEVEL port. Plug the other end into the remote module. Install the module within easy reach on or under your dash.

SPEAKER WIRING AND CONFIGURATIONS

Speaker Load

Keep in mind your DLS DD33-40 amplifier is a high power amplifier and not a high current amplifier. In other words **this amplifier requires a minimum impedance of 2 ohms STEREO and 4 ohms bridged (2-ohms MONO on SUB channel) to operate trouble free** Lower impedance will send the amplifier into protection and possibly damage the electronics inside and void the warranty.

NOTE: Know your total impedance load before you make any connections.

Speaker Wiring

Choose the correct speaker wire for your application. Most applications will require a minimum of 16 gauge wire. At the amplifier end, splice the speaker wires to the properly marked output leads from the Molex style connector. Route these using the same precautions as you did when you ran the power cable. Check to make sure you've maintained proper polarity and balance.

CAUTION:

Maintaining proper impedance is critical when wiring the Full Range Digital model amplifiers. Improper wiring can cause severe damage to BOTH the speakers and the amplifier. Detailed wiring diagrams are supplied with all DLS woofers. IF YOU ARE NOT EXPERIENCED OR UNCOMFORTABLE READING THE WIRING DIAGRAMS CONSULT YOUR AUTHORIZED DLS DEALER BEFORE YOU ATTEMPT TO WIRE THE SYSTEM.



PLEASE OBSERVE POLARITY AS SHOWN ON WIRE MARKERS.

Speaker Output Connections 3 Channel Model (DD33-40)

1. 3-Channel Speaker Output Connection

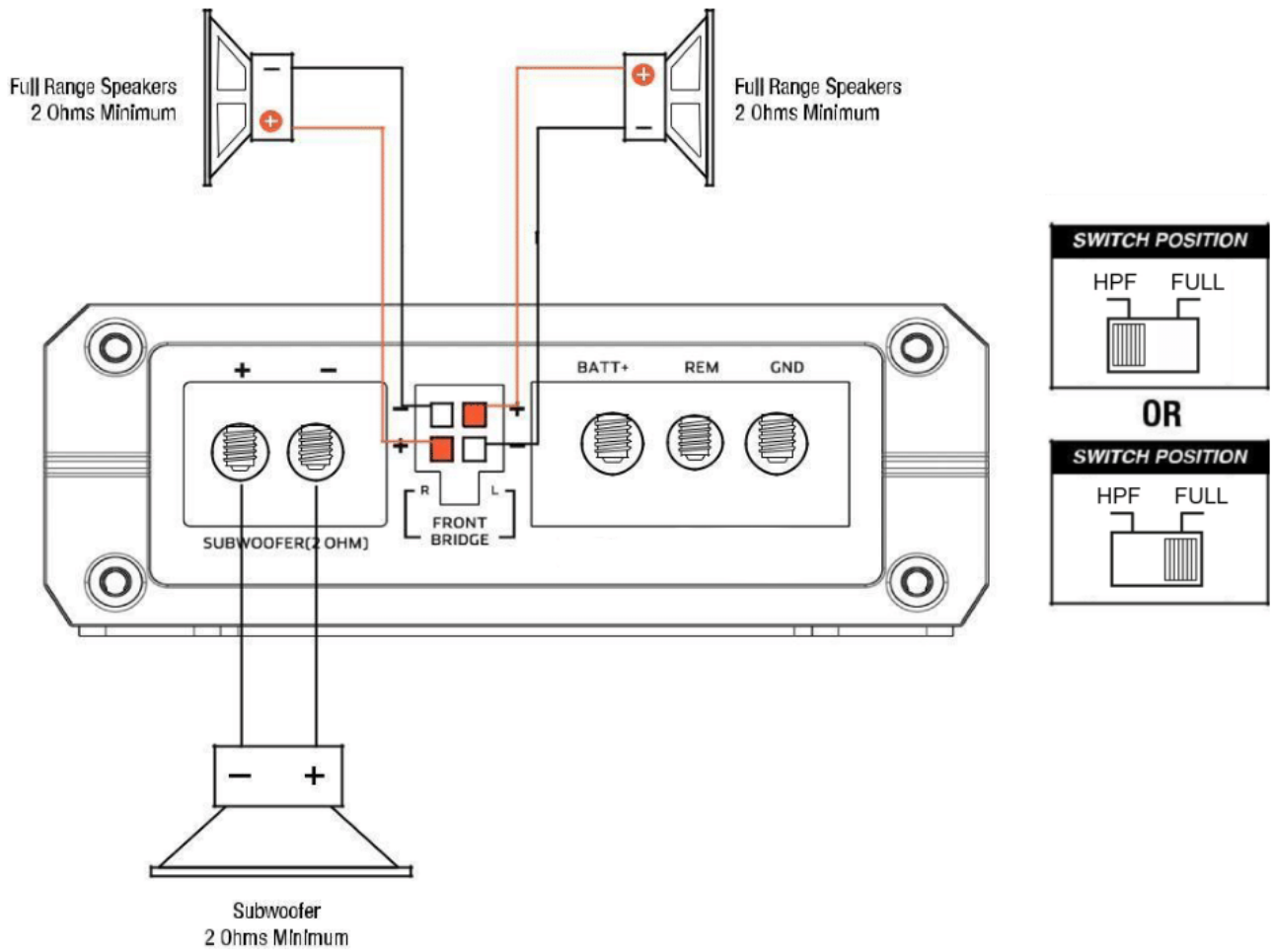

Fig.12 3-CH Speaker Connection
(Do not connect total impedance under 2 ohms)



TROUBLESHOOTING TIPS

| Problem | Solution |
|--|---|
| Power LED not ON | With a Volt Ohm Meter (VOM) check: <ul style="list-style-type: none">• +12 Volt power terminal (should read +10 to +16V DC)• Remote turn on terminal (should read +10 to +16V DC)• Ground Terminal |
| Power LED lights BLUE, no output | <ul style="list-style-type: none">• Check RCA connections• Test speaker outputs with known good speaker• Substitute known good Source Unit• Check for signal on the RCA cable with VOM in AC position. |
| Power LED lights BLUE, but volume reduces automatically. | <ul style="list-style-type: none">• Short circuit protection is engaged. Check for speaker wires shorted to each other or the vehicle chassis. |
| Red Status Protection LED is ON, no output and 1. Amp is VERY HOT 2. Amp shuts down ONLY when the vehicle is running 3. Amp has no output | <ul style="list-style-type: none">• Advanced Protection Circuitry is engaging due to high internal temperature of the amplifier. Amplifier requires more air flow around the chassis. If this continues choose a better ventilated mounting location.• Voltage protection engaged. Voltage to the amp is not within the 10-16 VDC operating range. Have the battery/ charging system inspected.• Possible short circuit. Check speaker wiring. Must completely turn off amplifier and restart to resume play. |
| Alternator noise (varies with RPM) | <ul style="list-style-type: none">• Check for damaged RCA cable.• Check routing of RCA cable• Check Source Unit for good ground• Check amp gain setting, turn down if set too high |
| Poor Bass Response | <ul style="list-style-type: none">• Check speaker polarity, reverse the connection of one speaker only. |

NOTE: After using all the troubleshooting tips above, if the Status L.E.D. is activated and glows RED with no speakers connected to the amplifier, and all the power connections are correct, this would indicate an internal problem with the amplifier. Contact DLS Sweden or your local dealer.



Specifications

DD33-40

| | |
|-----------------------------------|-----------------|
| Number of channels | 3 |
| Amplifier class | D |
| Power output RMS, 2 ohm (1%THD) | 95Wx2+300W |
| Peak music power, 2 ohm | 490 W |
| Power output RMS, 4 ohm (1%THD) | 75Wx2+200W |
| Signal to noise ratio, A-weighted | >90 dB |
| Damping factor | >80 |
| Frequency response | 10 Hz - 20 kHz |
| Input impedance, low level | 22 kohm |
| Input sensitivity | 250mV - 5V |
| Input impedance, high level | 40 ohm |
| High level input with auto start | Yes |
| Filter low pass variable | 50-250 Hz |
| Filter High pass variable | 40-400 Hz |
| Bass boost | +0-12 dB |
| Remote sub level control | Yes |
| Power consumption, idle | 0,6 A |
| Power consumption, max | 60A |
| Recommended Fuse | 40A |
| Dimensions HxWxD(mm) | 35 x 103 x 215 |
| Dimensions (inch) | 1,4 x 4,0 x 8,5 |
| Weight | 3 kg |
| Voltage | 10-16V |

***REQUIRES EXTERNAL FUSE !**

Important Notes:

-Due to continuing improvements these specifications are subject to change without any notice.

-Do not attempt to fix or repair this unit. Unauthorized repairs will void the manufacturer's warranty

Thank you for choosing DLS
enjoy...