



...connecting to the aftermarket

APPLICATIONS

Mazda 6 2006-2008

CT24MZ06



KIT FEATURES

- DIN Head Unit Provision
- ISO DIN Head Unit Provision

KIT COMPONENTS

A) Radio/Climate Control Housing Assembly • B) ISO Brackets • C) ISO Trim Plate • D) Harnesses

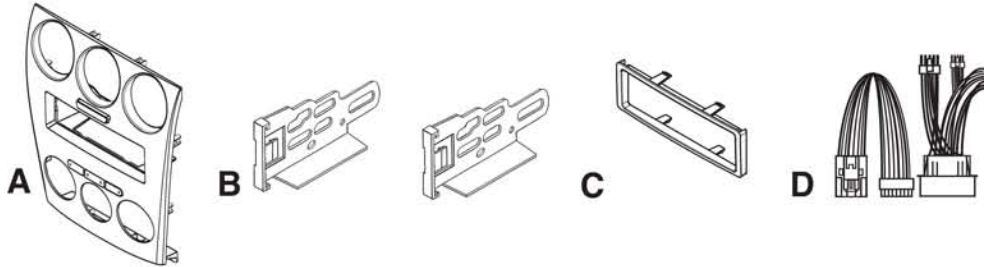

TOOLS REQUIRED:

Phillips Screwdriver | Small Flat Blade Screwdriver | Socket Wrench



www.connects2.com

TABLE OF CONTENTS

<i>Dash Disassembly</i>	1-5
<i>Electronic Climate Control</i>	1-2
<i>Manual Climate Control</i>	3-5
<i>Kit Assembly</i>	6-8
<i>Electronic Climate Control</i>	6
<i>Manual Climate Control</i>	7-8
<i>Felt Tape Application</i>	9
<i>Display Customization</i>	10
<i>Final Wiring and Assembly.</i>11,12

MAZDA 6 2006-2008

Electronic Climate Control

- 1** Disconnect the negative battery terminal to prevent an accidental short circuit.
- 2** Unscrew the shift knob counter clockwise to remove. (Figure A)
- 3** Unclip and remove the cup holder/parking brake cover and shifter cover as one unit. (Figure B)
- 4** Remove (2) Phillips screws from the bottom of the radio/climate control panel. (Figure C)
- 5** Open glove box, squeeze sides together and let open fully then remove (1) 10 MM bolt from the side of the radio bracket. (Figure D)

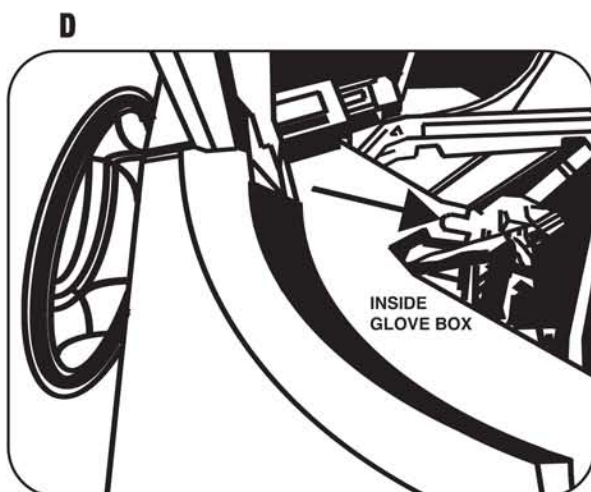
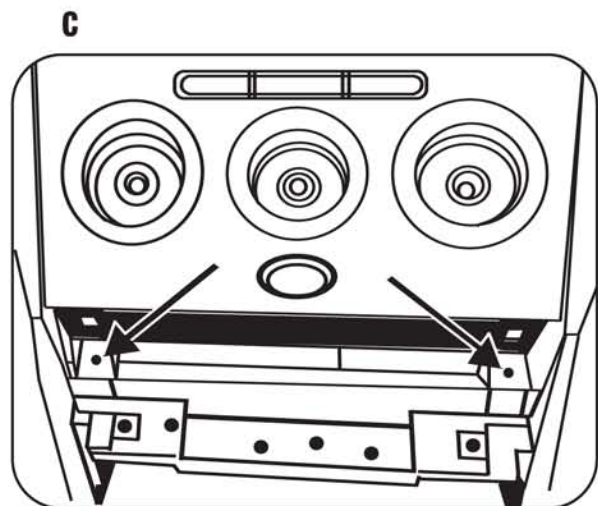
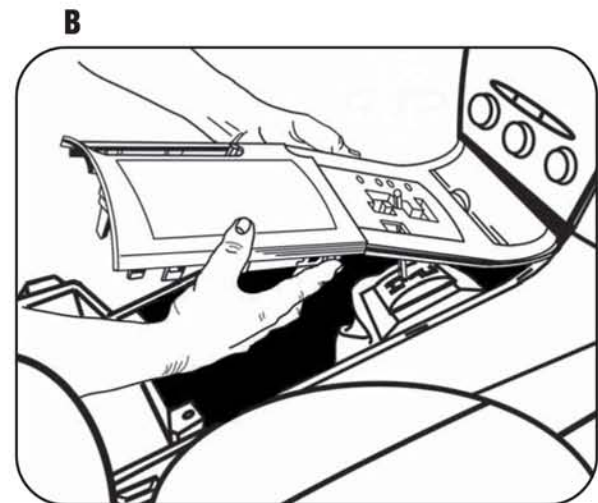
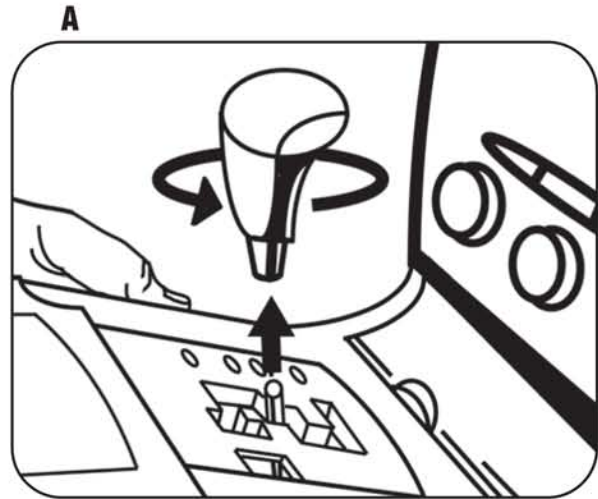

MAZDA 6 2006-2008

Electronic Climate Control

6 Unsnap and remove radio/climate control panel including climate control vents at the top. (Figure E)

7 Remove (4) Phillips screws securing vents to radio/climate control panel to remove. (Figure F)

8 Remove (8) Phillips screws securing the electronic climate control to the radio/climate control panel to remove. (Figure G)

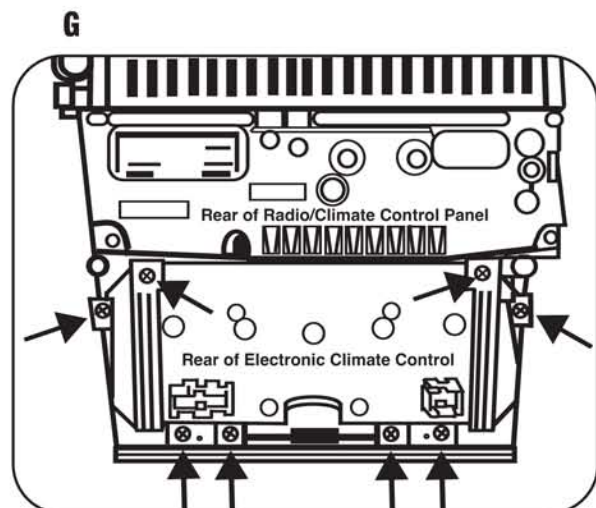
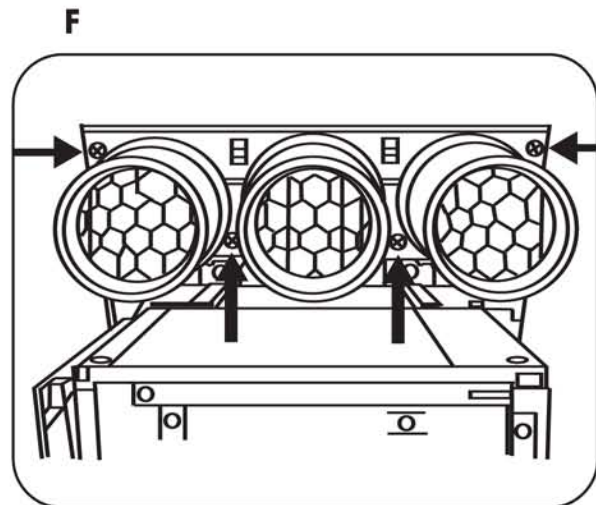
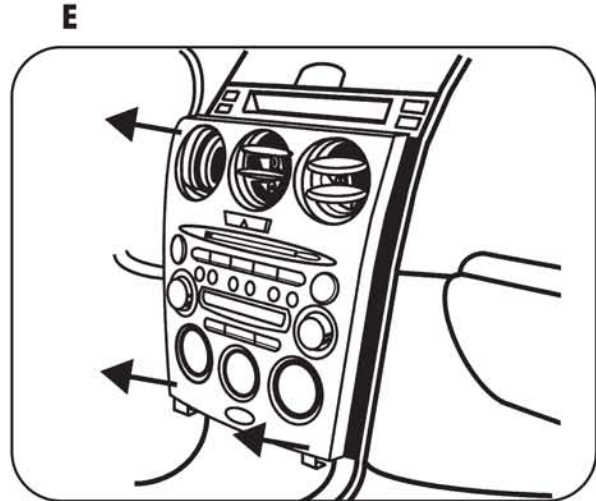

MAZDA 6 2006-2008

Manual Climate Control

- 1** Disconnect the negative battery terminal to prevent an accidental short circuit.
- 2** Unscrew the shift knob counter clockwise to remove. (Figure A)
- 3** Unclip and remove the cup holder/parking brake cover and shifter cover as one unit. (Figure B)
- 4** Remove (2) Phillips screws from the bottom of the radio/climate control panel. (Figure C)
- 5** Pull the climate control knobs off and remove (2) Phillips screws from behind knobs. (Figure D)

A

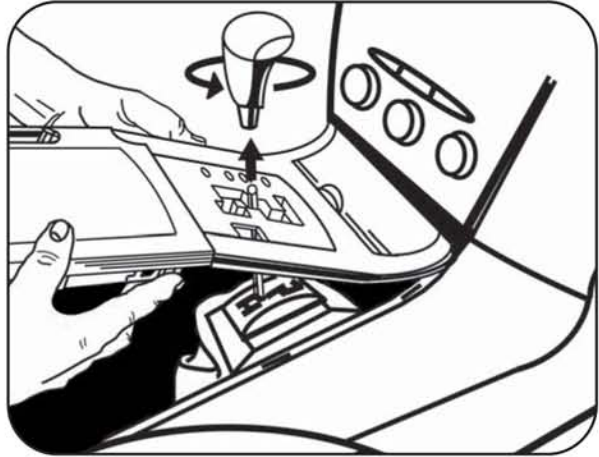

B

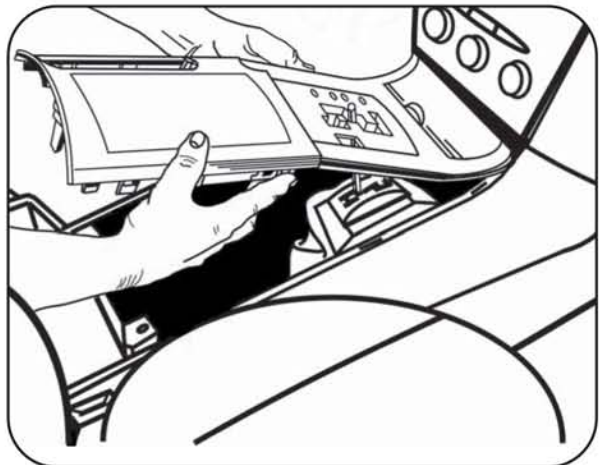

D

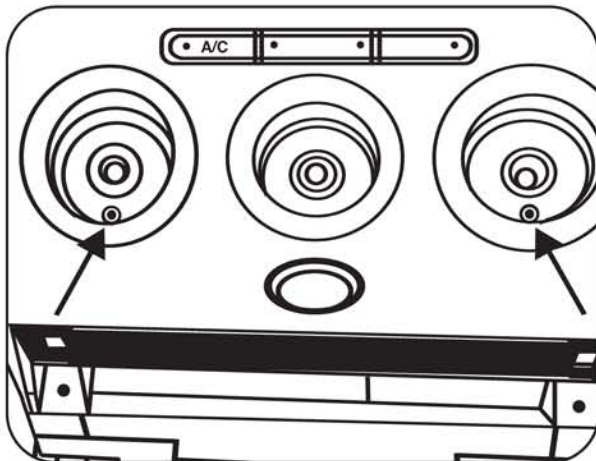

C

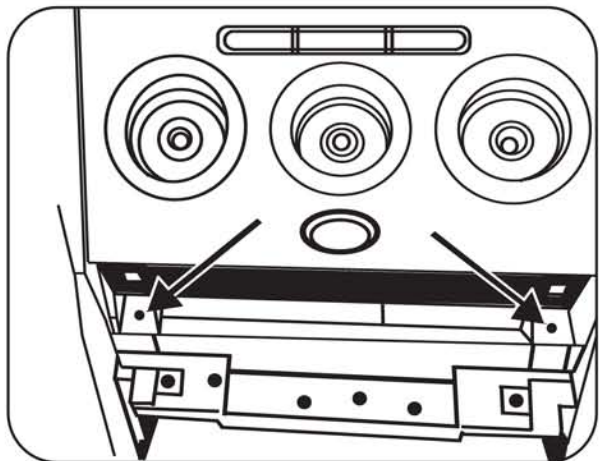

MAZDA 6 2006-2008 Manual Climate Control

6 Open glove box, squeeze sides together and let open fully then remove (1) 10 MM bolt from the side of the radio bracket. (Figure E)

E

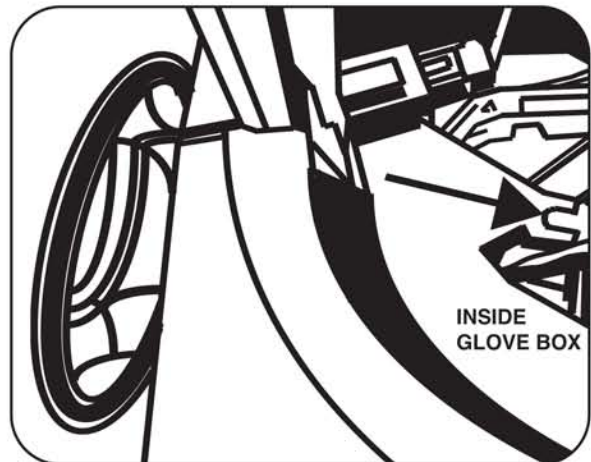

7 Unsnap and remove radio/climate control panel including climate control vents at the top. (Figure F)

F

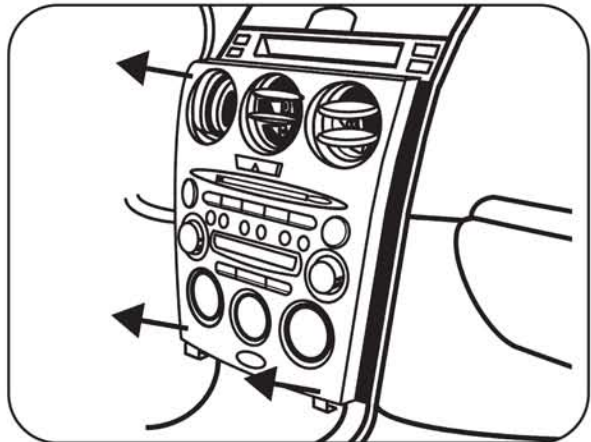

8 Remove (4) Phillips screws securing vents to radio/climate control panel to remove. (Figure G)

9 Remove the (2) small Phillips screws securing the light bulb boards on each side of the backlight dispersion bar. **Note:** Notice how they are positioned in the backlight dispersion bar as they will be placed in the **facia** the same way. (Figure H)

G

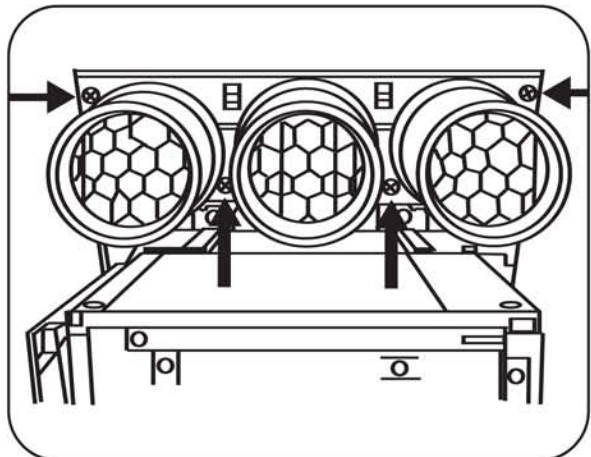

H

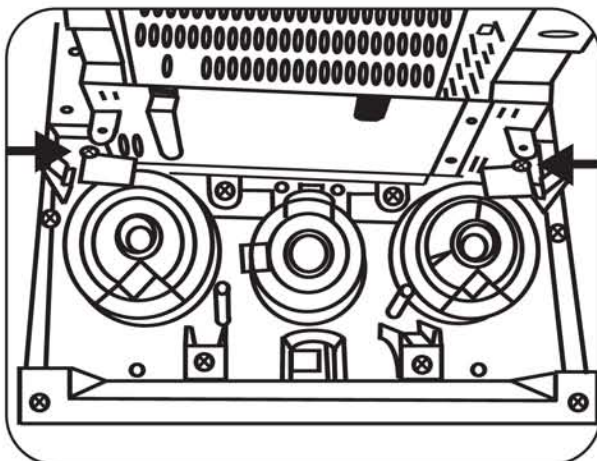

MAZDA 6 2006-2008 **Manual Climate Control**

10 Remove (4) Phillips screws securing backlight dispersion bar and knob trim bezels. (Figure I)

11 Push the bottom edges of the knob trim bezels from the front side to the back and slide both pieces out as one unit. (Figure J)

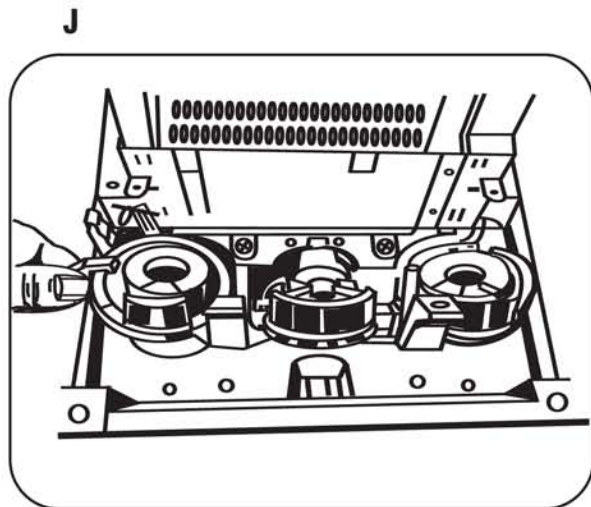
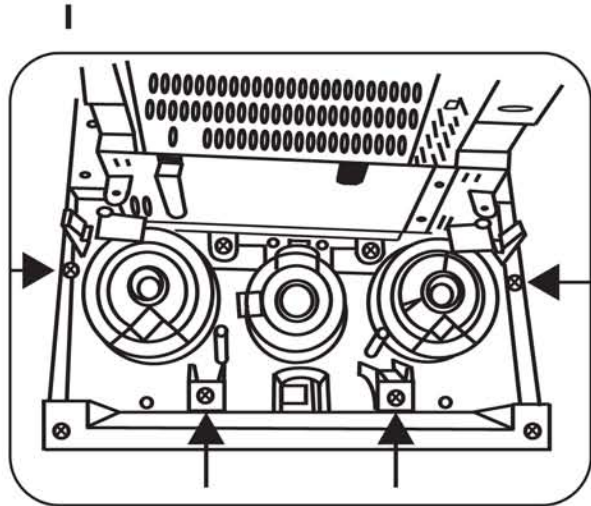

MAZDA 6 2006-2008

Electronic Climate Control

- 1** Clip the climate control knob outer trim ring panel into the **facia** housing. (Figure A)
- 2** Align the screw holes in the climate control and the radio housing panel then push the climate control onto the radio housing panel. (Figure B)
- 3** Secure the climate control with the factory hardware removed in step 8 of the dash disassembly for electronic climate control cars.
- 3** Unclip and remove the small oval cover plate at the bottom center of the factory radio and insert into the **facia** radio housing. (Figure C)

Note: The 16 position to 16 position harness supplied with the **facia** will NOT be used in vehicles with electronic climate controls. (Figure D)

A

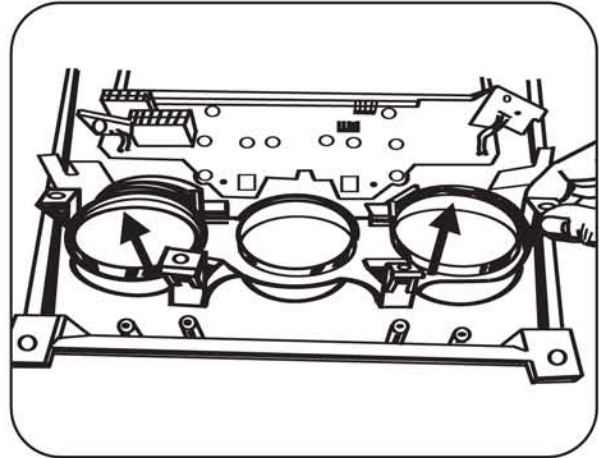

B

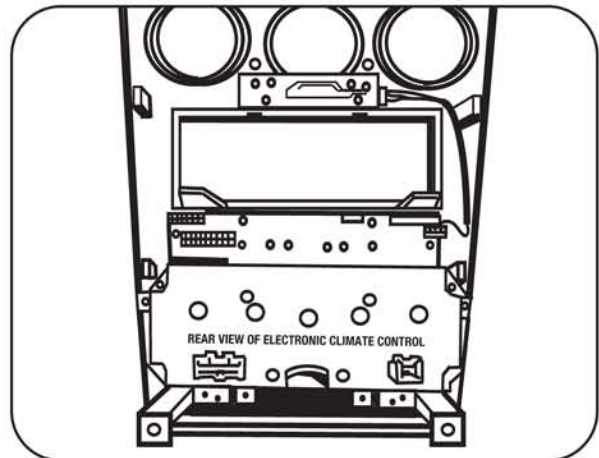

C

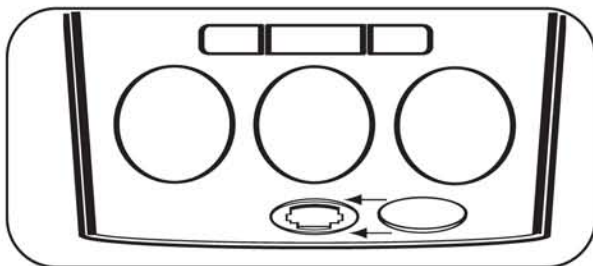

D

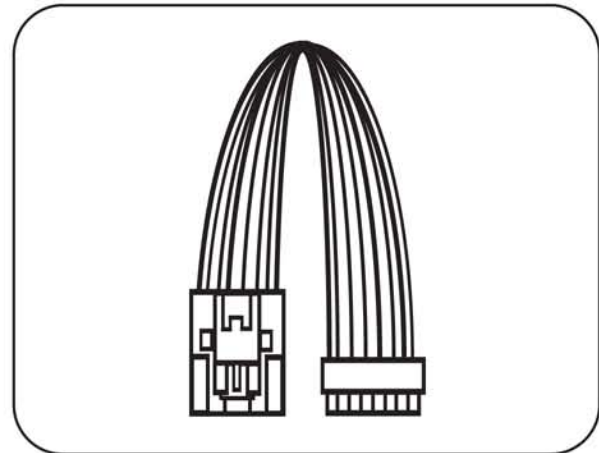

MAZDA 6 2006-2008

Manual Climate Control

- 1 Put the climate control knob outer trim panel and the backlight dispersion bar together and clip into the radio housing panel as one unit.
Note: You may have to push down slightly on the middle of the unit to ease in positioning it into the kit. (Figure A, B, C)

- 2 Secure the unit with the factory hardware removed in step 10 of the manual climate control dash disassembly.

- 3 Secure the light bulb boards on each side of the backlight dispersion bar using the factory hardware removed in step 9 in manual climate control dash disassembly. (Figure D)

- 4 Unclip and remove the small oval cover plate at the bottom center of the factory radio and insert into the **facia** radio housing. (Figure E)

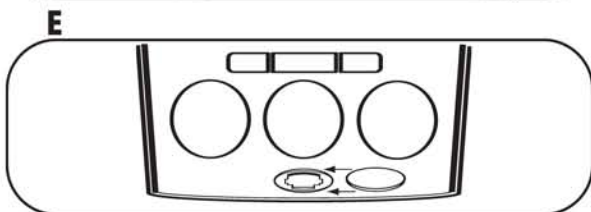
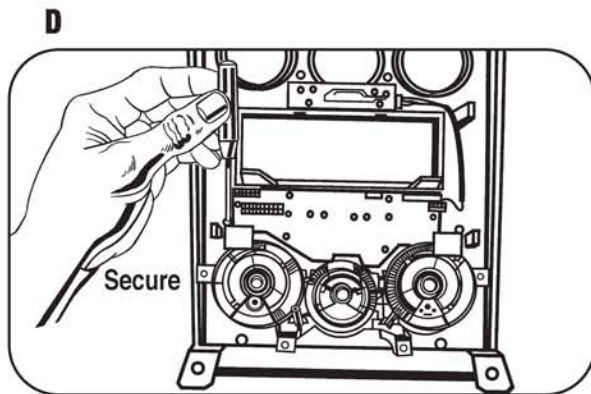
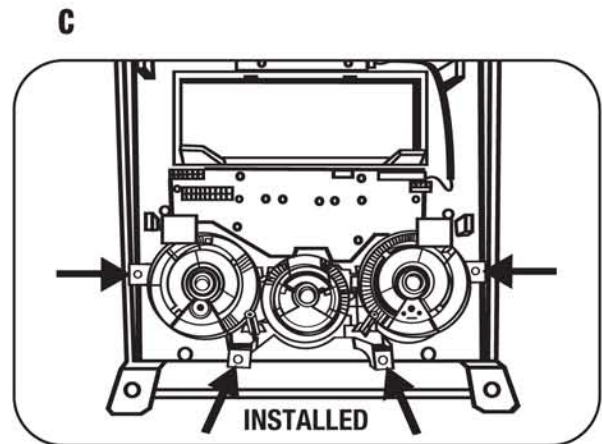
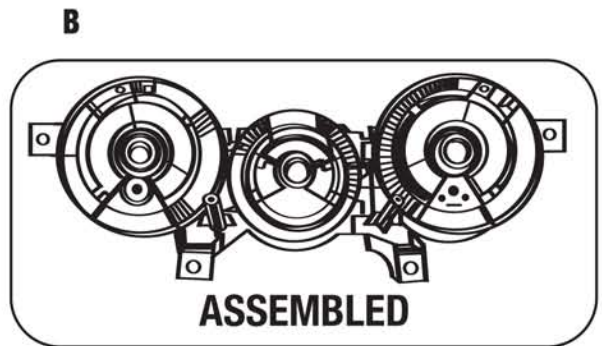
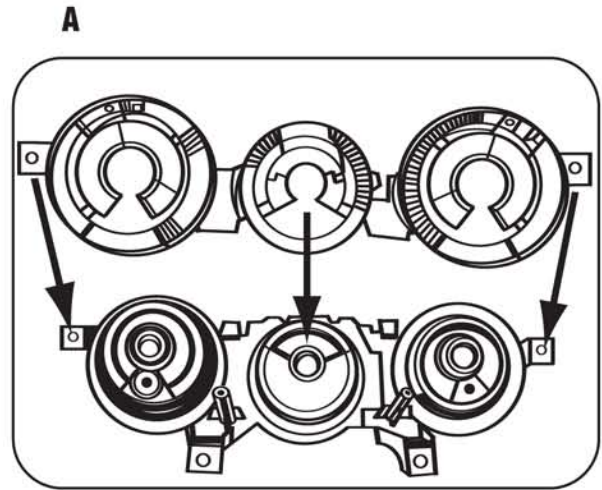

Note: The 16 position to 16 position harness supplied with the **facia** WILL be used in vehicles with manual climate controls. (Figure F)

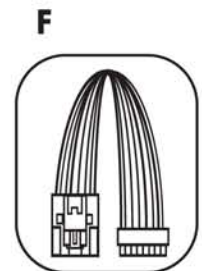

DIN HEAD UNIT PROVISION

- 1 Slide the DIN cage into the Radio Housing and secure by bending the metal locking tabs down. (Figure A)
- 2 Slide the aftermarket head unit into the DIN cage until secure. (Figure B)

A

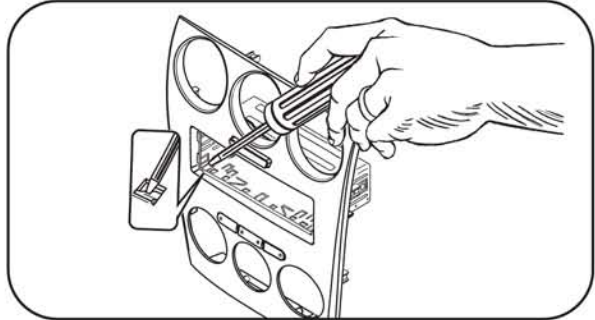

B

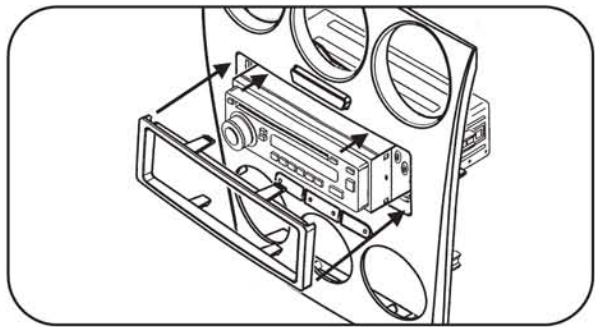

- 3 Snap the Trim plate into the Radio Housing. (Figure B)

ISO DIN HEAD UNIT PROVISION

- 1 Mount the ISO Brackets to the head unit with the screws supplied with the unit. (Figure A)
- 2 Slide the head unit into the radio opening until the side clips engage. (Figure B)
- 3 Snap the Trim plate into the Radio Housing. (Figure B)

A

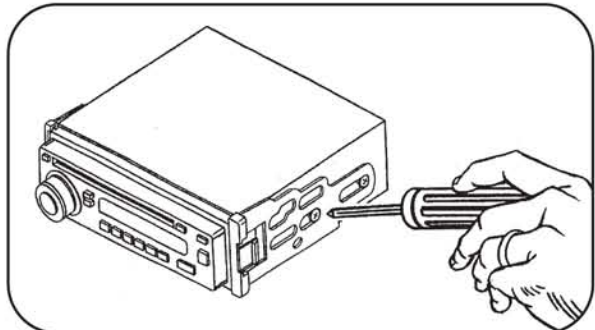

B

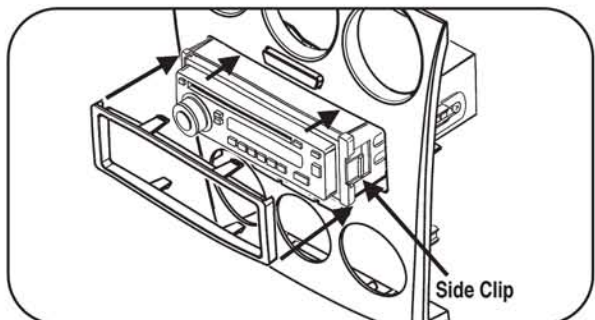

FELT TAPE APPLICATION

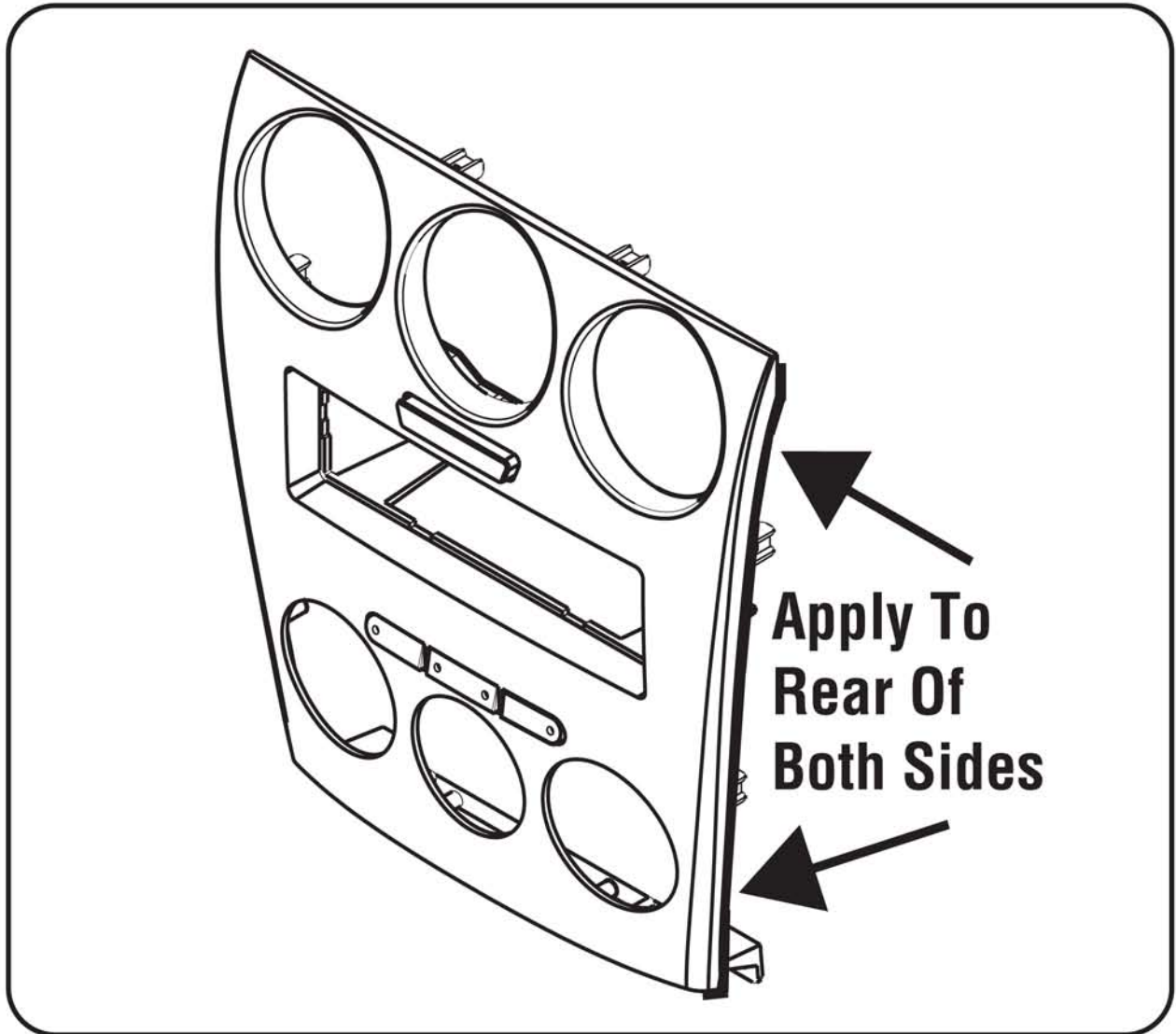

Note: Due to differences in factory tolerances you may need to apply the provided felt tape to the edge of the **facia** radio housing to relieve backlight bleed through.

1. Looking at edge of radio housing apply felt tape to inner edge (toward back of kit). If it is positioned to closely to the outer edge you may be able to see it once it is in the dash.

DISPLAY CUSTOMIZATION

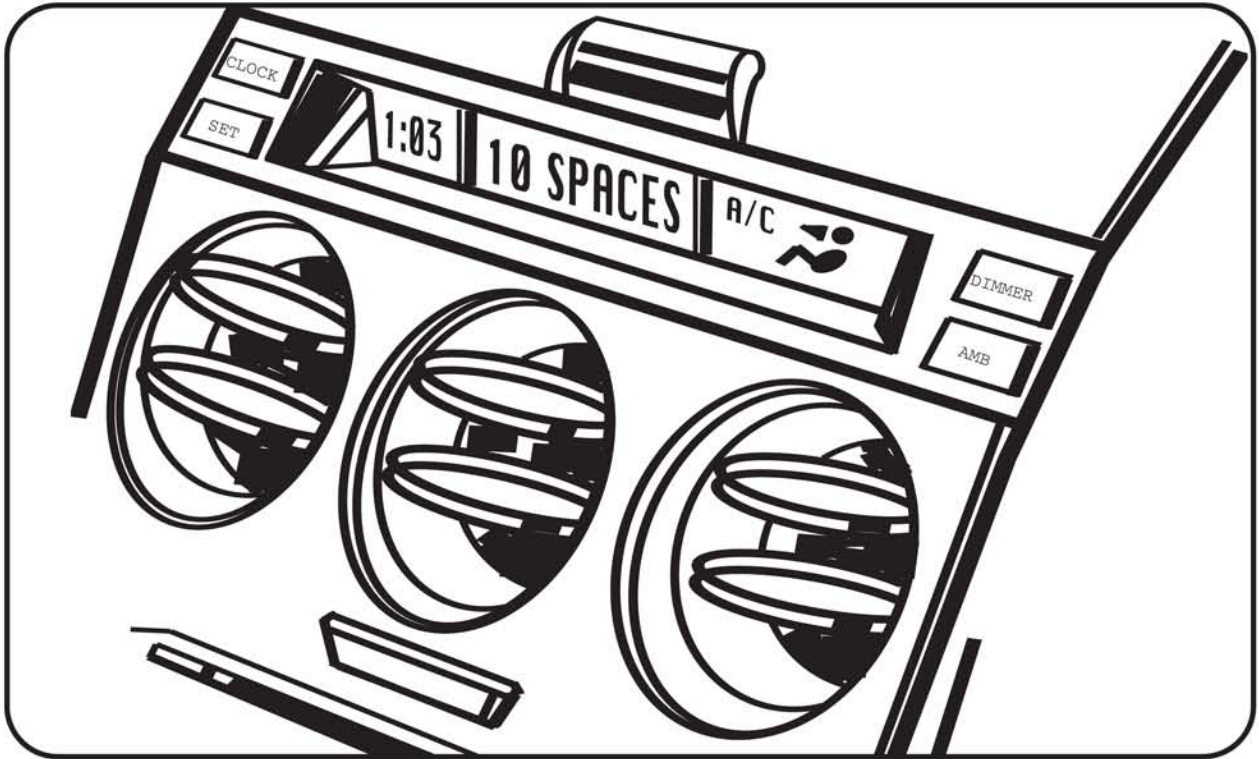

1. Press and hold the **AMB button** on the factory display for 5 seconds then release the button. The first character will be highlighted. Settings will begin with the first character location. Use the **AMB button** to select the desired character then wait. The next character will be highlighted. Press and release to set that character, and keep going until the text is to your liking. There are 10 available character locations.

2. Once the desired text is entered press and hold the **AMB button** for greater than 5 seconds then release and the display will read **“Text Saved.”**

FINAL ASSEMBLY

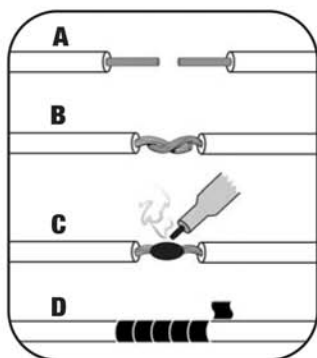

- (A) Strip wire ends back 1/2"**
- B) Twist ends together**
- C) Solder**
- D) Tape**

- 1 Locate the factory wiring harness in the dash. **Connects2** recommends using the proper mating adapter and making connections as shown. (Isolate and individually tape off the ends of any unused wires to prevent electrical short circuit.)
- 2 Re-connect the negative battery terminal and test the unit for proper operation.
- 3 Reassemble radio and dash assemblies in reverse order of disassembly.

FINAL WIRING CONNECTIONS

Make wiring connections using the EIA color code chart shown below and the instructions included with the head unit. **Connects2** recommends making connections as shown below; Strip, Splice, Solder, Tape. Isolate and individually tape off ends of any unused wires to prevent electrical short circuit.

EIA WIRING CODE

12V Ignition / Acc.	Red	Right Front (+)	Gray
12V Batt / Memory	Yellow	Right Front (-)	Gray/ Black
Ground	Black*	Left Front (+)	White
Power Antenna	Blue	Left Front (-)	White / Black
Amp Turn-On	Blue / White	Right Rear (+)	Violet
Amp Ground	Black / White	Right Rear (-)	Violet / Black
Illumination	Orange	Left Rear (+)	Green
Dimmer	Orange / White	Left Rear (-)	Green / Black

***NOTE:** When a Black wire is not present, ground radio to vehicle chassis.
All colors may not be present on all leads due to manufacturer's specifications.